

PRODUCT INFORMATION PACKET

Model No: 056C17W5338
Catalog No: N682
1,1725,TEFC,56,1/60/115/208-230
Washdown Duty



Regal and Marathon are trademarks of Regal Beloit Corporation or one of its affiliated companies.

©2018 Regal Beloit Corporation, All Rights Reserved. MC017097E





Nameplate Specifications

Output HP	1 Hp	Output KW	0.75 kW
Frequency	60 Hz	Voltage	115/208-230 V
Current	12.8/6.4 A	Speed	1725 rpm
Service Factor	1.15	Phase	1
Efficiency	75 %	Duty	Continuous
Insulation Class	F	Design Code	N
KVA Code	K	Frame	56
Enclosure	Totally Enclosed Fan Cooled	Overload Protector	No
Ambient Temperature	40 °C	Drive End Bearing Size	6205
Opp Drive End Bearing Size	6203	UL	Recognized
CSA	Y	CE	N
IP Code	55		

Technical Specifications

Electrical Type	Capacitor Start Induction Run	Starting Method	Across The Line
Poles	4	Rotation	Selective Counterclockwise
Mounting	Rigid base	Motor Orientation	Horizontal
Drive End Bearing	Ball	Opp Drive End Bearing	Ball
Frame Material	Rolled Steel	Shaft Type	Single Special Extension
Overall Length	11.81 in	Shaft Diameter	0.625 in
Shaft Extension	1.88 in	Assembly/Box Mounting	F1 Only
Outline Drawing	034909-600	Connection Diagram	00527801ME

This is an uncontrolled document once printed or downloaded and is subject to change without notice. Date Created: 06/29/2018

034909

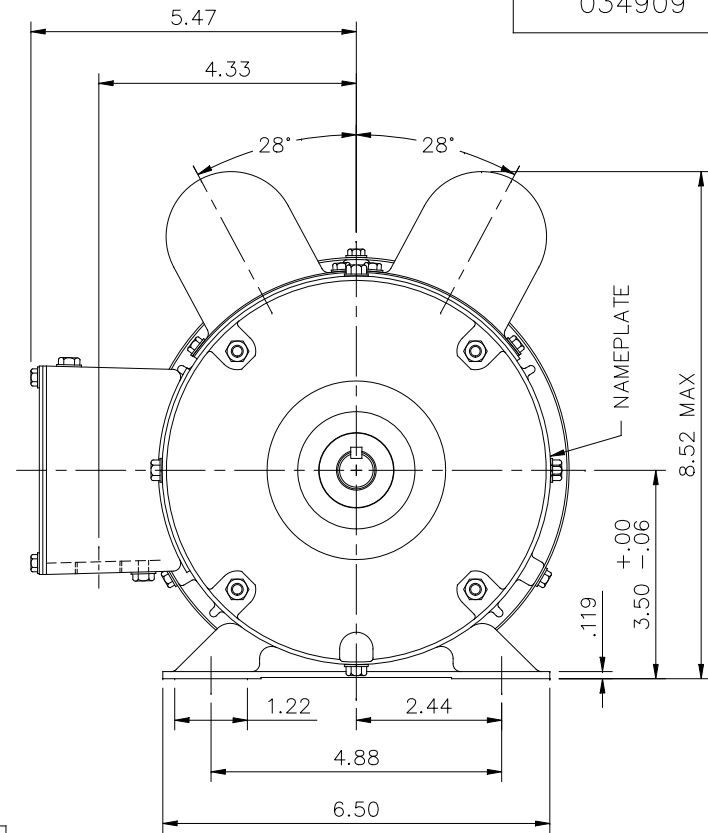
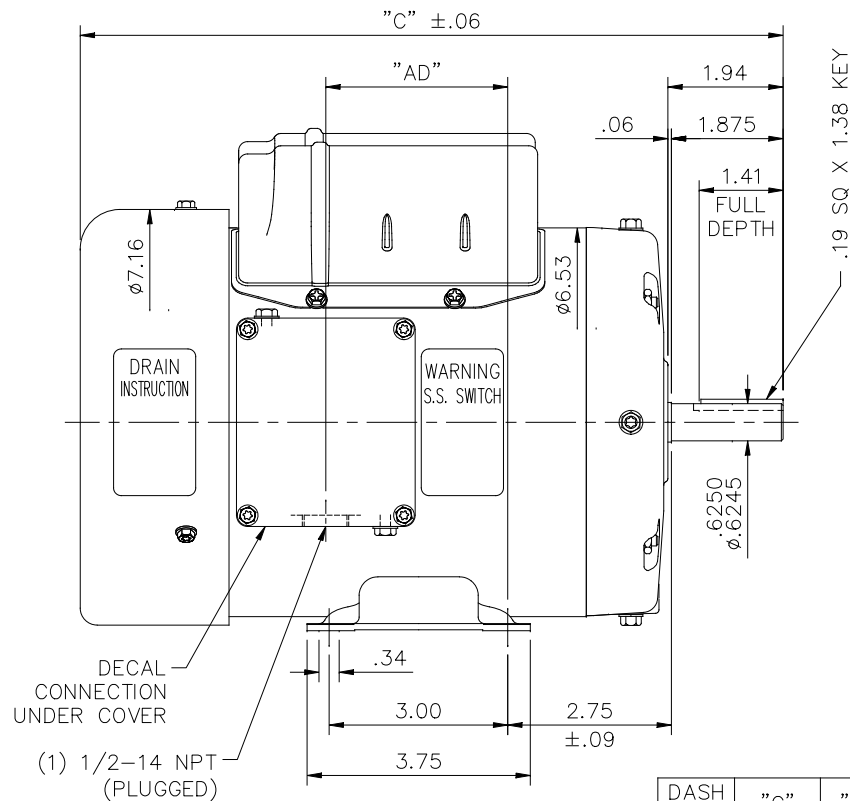

SPECIAL FEATURES:

- 1) SHAFT SEALS & V-RING
- 2) DRAIN HOLES IN ENDBELLS & CONDUIT BOX
- 3) STAINLESS STEEL SHAFT, HARDWARE & NAMEPLATE
- 4) GASKETS THROUGHOUT

DASH NO.	"C"	"AD"
500	10.81	2.06
550	11.31	2.56
600	11.81	3.06
650	12.31	3.56

ORACLE REV
04

		TOLERANCES UNLESS SPECIFIED		MARATHON ELECTRIC	DRAWN RDW 12/13/01		
		DEC.	INCHES		CHK		
		.X	±.1	TITLE OUTLINE - 56C FRAME TEFC - RIGID	APPD	KMM 12/13/01	
		.XX	±.03		SCALE	3=8	
		.XXX	±.005		REF	112626	
F	ADDED DRAIN SCREW PER ECO-0125132	ARV	6/12/17	SK	.XXXX	±.0005	MAT'L.
NO.	REVISION	BY & DATE		CHK	ANG	±1/2"	FINISH
THIS DRAWING IN DESIGN AND DETAIL IS OUR PROPERTY AND MUST NOT BE USED EXCEPT IN CONNECTION WITH OUR WORK ALL RIGHTS OF DESIGN AND INVENTION ARE RESERVED THIS IS AN ELECTRONICALLY GENERATED DOCUMENT - DO NOT SCALE THIS PRINT				RFP	12/13/01	CAD FILE	034909
				DIST		SIZE	DRAWING NO.
						A	034909
							REV.
							F

VIEW FROM OUTSIDE OF MOTOR AT SWITCH END

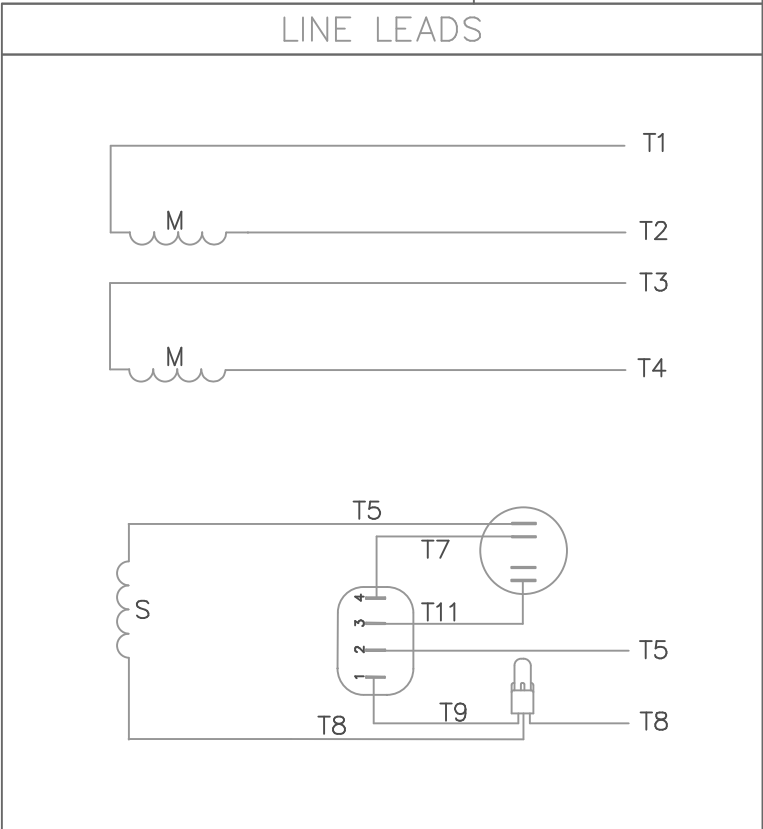
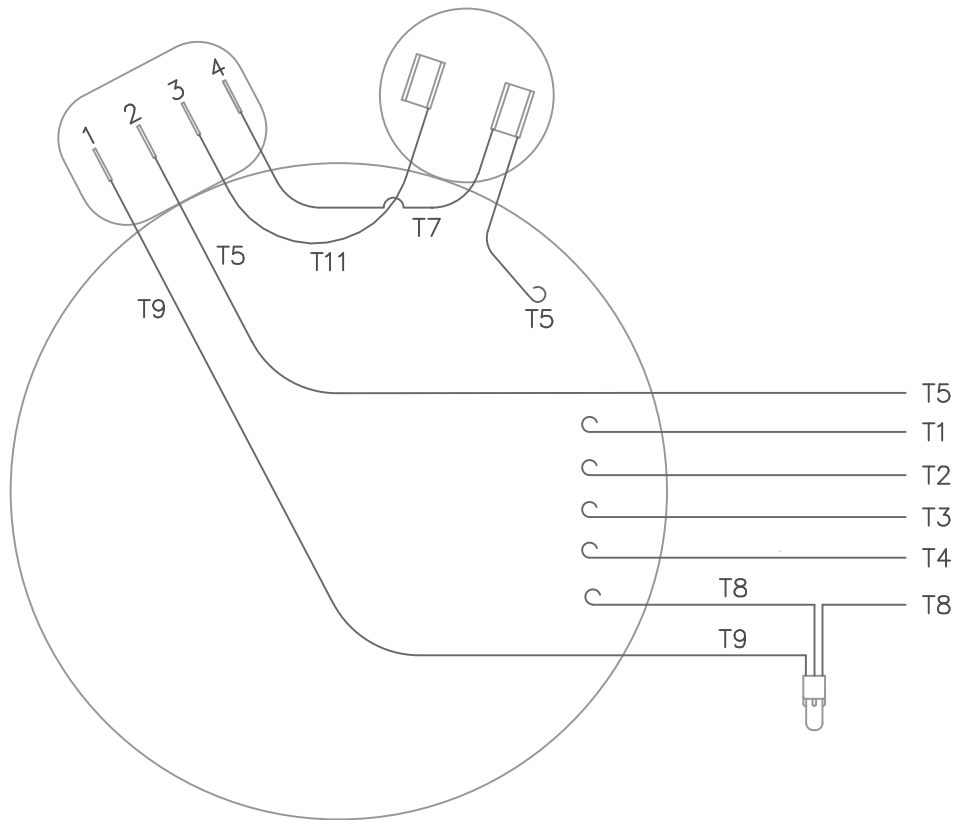

	ROTATION FACING LEAD END	L1	L2	JOIN & INSULATE
HIGH VOLT	C.C.W.	T1	T4 T5	T2,T3 T8
	C.W.	T1	T4 T8	T2,T3 T5
LOW VOLT	C.C.W.	T1,T3 T8	T2,T4 T5	
	C.W.	T1,T3 T5	T2,T4 T8	

		TOLERANCES UNLESS SPECIFIED				DRAWN RDW 04/18/02	
		DEC.	INCHES			CHK	
		.X	±.1			APPD KMM 04/18/02	
		.XX	±.01			SCALE 1=1	
		.XXX	±.005			REF	
		.XXXX	±.0005	MAT'L. DECAL - 004012		FMF	
NO.	REVISION	BY & DATE	CHK	ANG	±1/2'	PREV	
THIS DRAWING IN DESIGN AND DETAIL IS OUR PROPERTY AND MUST NOT BE USED EXCEPT IN CONNECTION WITH OUR WORK ALL RIGHTS OF DESIGN AND INVENTION ARE RESERVED THIS IS AN ELECTRONICALLY GENERATED DOCUMENT - DO NOT SCALE THIS PRINT			RFP	04/18/02	CAD FILE	00527801ME	SIZE DRAWING NO.
			DIST			A	005278-01ME
							REV.

